

TECHNICAL BULLETIN

No. 692B

Chockfast® GENERAL GUIDELINES FOR MARINE DESIGNERS

GENERAL GUIDELINES

The CHOCKFAST system is used for mounting all sizes and types of main and auxiliary machinery. It eliminates all machining of foundation surfaces and will conform precisely to the surface profiles presented. The individual chocks are arranged similarly to conventional iron ones. Removal of grease, oil, mill scale and/or rust or flaky paint is the only preparation usually necessary for machinery supporting surfaces. These surfaces should be cleaned if covered by other than a thin coat of inorganic zinc paint or similar primer. Inorganic zinc is recommended where machinery base and foundation corrosion resistance is required, as in the case of deck machinery and other equipment constantly exposed to water.

Which Grade of CHOCKFAST to Use

When alignment must be maintained precisely, or when the operating temperature will exceed 52°C (125°F) but not 90°C (194°F), then CHOCKFAST ORANGE® must be used. Examples of this class of machinery are propulsion engines and gearboxes.

Where alignment does not have to be maintained precisely, usually because the equipment is self-contained, and the operating temperature will be below 52°C (125°F), then CHOCKFAST ORANGE or CHOCKFAST GRAY® may be used. Typical applications would be winches, pumps and skid mounted diesel generators.

Design for Precise Alignment

(Propulsion machinery, etc.)

a. Stress on the chocks due to the machinery's weight, known as deadweight loading, may be limited by the applicable classification society. Standard values are 7 kgf/cm²-9 kgf/cm² (100 psi-130 psi). Limits of deadweight loading if any, should be determined prior to beginning a design.

b. Static stress on the chocks due to the Deadweight plus the Bolt Tensions is typically designed to be 35 kgf/cm² (500 psi). Most classification societies approve a sliding scale of static stress vs. chock operating temperature. For example, 45 kgf/cm² (640 psi) at 80°C (176°F). Check with the appropriate classification approval.

c. Hold down bolt tensions must total at least 2.5 times the machinery weight. This is to ensure the machine will not move.



d. Hold down bolt stress must be at least 4.73 kgf/mm² (6720 psi). This is to ensure the bolts will stay tight.

e. Continuous chock temperature should not exceed 90°C (194°F). Unless otherwise stated it may be assumed that a diesel engine's chocks will exceed 80°C (176°F).

f. Where thrust has to be transmitted, thrust chocks are not required if the total static chock loads exceeds 3.33 times the thrust.

Any thickness of chock can be cast. For ease of installation 12mm to 45mm (1/2" to 1 3/4") thick chocks work well.

Design for Deck and Auxiliary Machinery

If the temperature will not exceed 52°C (125°F), machinery and equipment which does not have to be precisely aligned may be chocked as follows:

Using CHOCKFAST ORANGE, maximum continuous static stress 84.5 kgf/cm² (1200 psi). Using CHOCKFAST GRAY, maximum continuous static stress 56 kgf/cm² (800 psi). It is not necessary to limit the deadweight loading. Chock thickness recommendations are as for precise alignment.

Design for Higher Stress than 84.5 kgf/cm² (1200 psi), Non-Critical Alignment

When the chock stress will be above the previously given limits it is advisable to consult ITW Philadelphia Resins. Continuous stress of 250 kgf/cm² (3550 psi) has been approved for mooring winches and this is also a typical stress under crane rails. Transients and shock loads of 700 kgf/cm² (10000 psi) can be accepted with suitable design guidance.

General Guidelines for Marine Engineers

Bolt Tension and Tightening Torque

There is no absolute relationship between tightening torque and bolt tension. The generally accepted formula is:

$$\text{Torque (kgf.m)} = \frac{0.2 \times \text{Tension (kgf)} \times \text{Dia. (mm)}}{1000}$$

$$\text{Torque (lbs.feet)} = \frac{0.2 \times \text{Tension (lbs.)} \times \text{Dia. (inches)}}{12}$$

$$\text{Torque (N.m)} = \frac{0.2 \times \text{Tension (N)} \times \text{Dia. (mm)}}{1000}$$

As has been explained, there is a minimum desirable bolt stress and the following table gives the **MINIMUM** tension for various size bolts. *It is normally advantageous to use more than the minimum shown here.* When the bolt material is unknown, a safe maximum tension is 3 times the value given in this table.

DIAMETER (mm)	MINIMUM TORQUE (kg.m)	MINIMUM TENSION (kg)	DIAMETER (in)	MINIMUM TORQUE (lbs.ft)	MINIMUM TENSION (lb)
12	3	570	1/2"	20	1320
14	4	770	3/8"	30	2062
16	5	1000	3/4"	45	2970
18	7	1275	7/8"	75	4042
20	10	1570	1"	90	5279
22	12	1900	1 1/8"	126	6681
24	14	2265	1 1/4"	172	8248
27	16	2965	1 3/8"	230	9980
30	22	3670	1 1/2"	300	11877
33	30	4545	1 3/4"	380	13939
36	40	5555	1 3/4"	475	16166
39	50	6410	1 7/8"	580	18558
42	60	7145	2"	705	21115
45	75	8335	2 1/8"	845	23836
48	90	9375	2 1/4"	1005	26723
52	110	10580	2 3/8"	1180	29775
56	140	12500	2 1/2"	1375	32991
60	170	14165	2 3/8"	1600	36373
64	200	15625	2 3/4"	1830	39920
68	250	18382	2 7/8"	2090	43631

CONVERSION FACTORS

kgf.m to lbs.ft multiply by 7.23

N.m to kgf.m multiply by 0.102

lbs.ft. to kgf.m multiply by 0.138

kg to lbs multiply by 2.2

lbs to kg multiply by 0.45

QUANTITY TO ORDER

The quantity of CHOCKFAST required is the volume of the chocks plus their overpours. The second section of this bulletin, "Application Instructions — Marine", explains the overpours. It is advisable to order an extra 10% to allow for chock thickness variations and wastage. Damming foam, mixing blades, sealing putty, release agent and nonmelt grease are also available from ITW Philadelphia Resins. CHOCKFAST is packaged in premeasured units of resin and hardener as follows:

CHOCKFAST ORANGE: 3.4 kgs (7.5 lbs.) and 6.8 kgs (15 lbs.)
1966 cc (120 in³) and 4261 cc (260 in³)

CHOCKFAST GRAY: 5 kgs (11 lbs.) and 21.8 kgs (48 lbs.)
3064 cc (187 in³) and 13372 cc (816 in³)

CALCULATION EXAMPLE PROPULSION ENGINE

Engine Weight	75000 kg	150000 lbs. (A)
Bolts 18 bolts	M42	1 3/4"
Engine Weight x 2.5	187500 kg	375000 lbs.
Each bolt tension, ÷ 18	10417 kgf	20834 lbs.
Minimum permitted tension	7145 kgf	16166 lbs.
Therefore bolt requirements are satisfied		

$$\text{Minimum chock area} = \frac{75000}{7} = 10715 \text{ cm}^2 \quad \frac{150000}{100} = 1500 \text{ in}^2$$

Assume 18 chocks, each chock 596 cm² 83.4 in²

Bolt hole area 16 cm² 2.76 in²

Assume chock projects 19.5 cm 7 3/4"

$$\text{Chock length} = \frac{596 + 16}{19.5} = 31.5 \text{ cm} \quad \frac{83.4 + 2.76}{7.75} = 11 1/8"$$

Each chock is 315 x 195mm 11 1/8" x 7 3/4"

Application Instructions — Marine

GENERAL INSTRUCTIONS FOR USING ITW PHILADELPHIA RESINS POURABLE CHOCKING COMPOUNDS

These instructions apply to normal CHOCKFAST installations on steel foundations, where the chock thicknesses are within the range.

CHOCKFAST ORANGE	12mm-100mm	1/2" - 4"
CHOCKFAST GRAY	12mm-50mm	1/2" - 2"

Outside these ranges please consult your CHOCKFAST distributor for guidance.

I. MATERIALS REQUIRED

1. CHOCKFAST ORANGE. Calculate from the chock plan the amount required based on 1966 cc (120 cu. in.) per 3.4 kg (7.5 lb.) unit, 4260 cc (260 cu. in.) per 6.8 kg (15 lb.) unit. Have an extra 10% available for chock thickness variation, accidental loss, etc.

CHOCKFAST GRAY. Calculate from the chock plan the amount required based on 3065 cc (187 cu. in.), or 13374 cc (816 cu. in.) for the two unit sizes. Have an extra 10% available for chock thickness variation, accidental loss, etc.
2. Damming materials:
 - a. flexible damming
 - b. metal front dams
 - c. sealing compound
 - d. contact adhesive where necessary
3. ITW Philadelphia Resins Release Agent.
4. Nonmelt Grease.
5. Heavy duty hand electric drill with an operating speed of 200 rpm.
6. ITW Philadelphia Resins mixing blade, and spare.
7. Surface Thermometer. An immersion thermometer is also useful.
8. Eye shields or goggles.
9. Slitting knife.
10. Protective gloves.
11. PRT-59 or other suitable solvent for cleaning mixer blade and spillage.
12. If the steel temperature is below 13°C (55°F), have sufficient heaters available to raise it above 15°C (60°F).

II. PREPARATIONS

1. Check that all materials are available.
2. Try to store the resin and hardener at 20°C-25°C (68°F-77°F) for at least the last 12 hours before use. This ensures the most suitable mixing and pouring viscosity.

3. The machine's alignment should be correct and all bolt holes should have been drilled. If they have not, core the hole through the chock space and bedplate with a wooden plug or Armaflex tubing.
4. Clean all surfaces that the CHOCKFAST will contact. They should be free from oil, grease, water, rust or paint in poor condition. A good coat of primer is acceptable.

III. DAMMING

1. The picture sequence shows the general damming procedure. Follow the dimensions given on the chock plan for the particular machine.

Fig. 1: Trim Foam to Proper Height

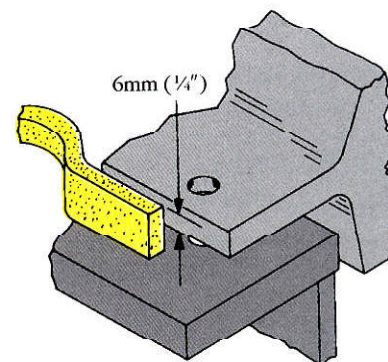

2. The bolt holes, except for fitted bolts, should preferably be plugged with Armaflex or wooden dowels. Alternatively the bolts may be in place with the nuts finger tight. Whatever is used to core the hole must be well coated with nonmelt grease

Fig. 2: Insert Damming per Chocking Plan

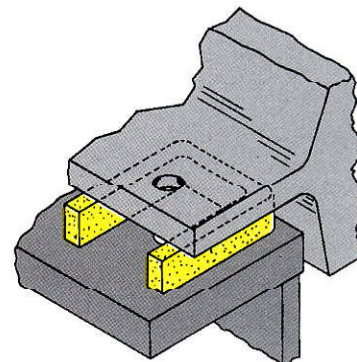

- Fitted bolts should be sprayed with ITW Philadelphia Resins Release Agent and installed.

Fig. 3: Plug Bolt Holes (with well greased plugs) Spray Chock Zone with thin film of release agent.

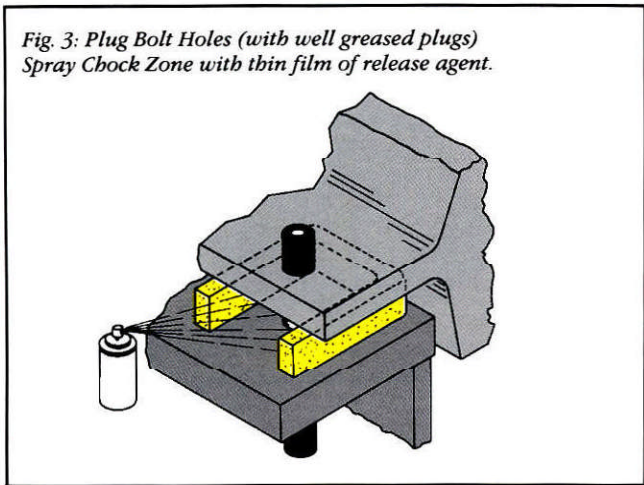

- Attach the front dam so that the overpour width and height will be within the limits shown. This is important.

Fig. 4: Tackweld Front Dam. Insert Overpour Damping Components

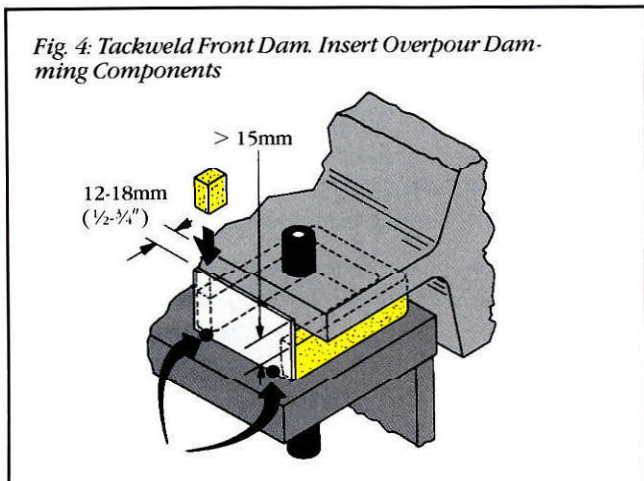

- Make sure all potential leaks are well sealed. It is easier to prevent leaks before the resin is poured than to stop them afterwards.

Fig. 5: Seal Front Dam at Bottom. Spray Its Inside Face With Release Agent

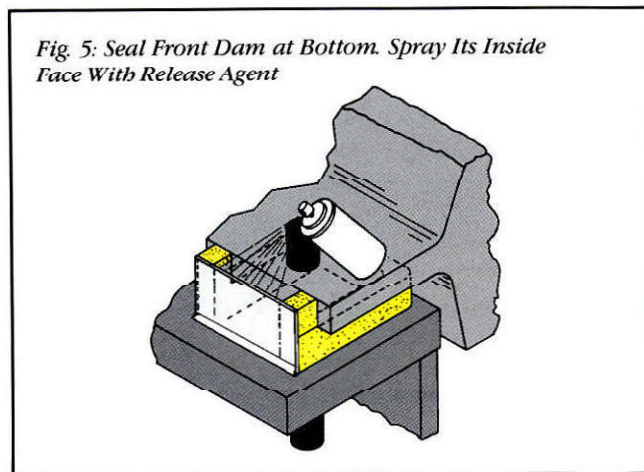

- Measure chock thickness and the temperatures of the engine bed and foundation.

Fig. 6:

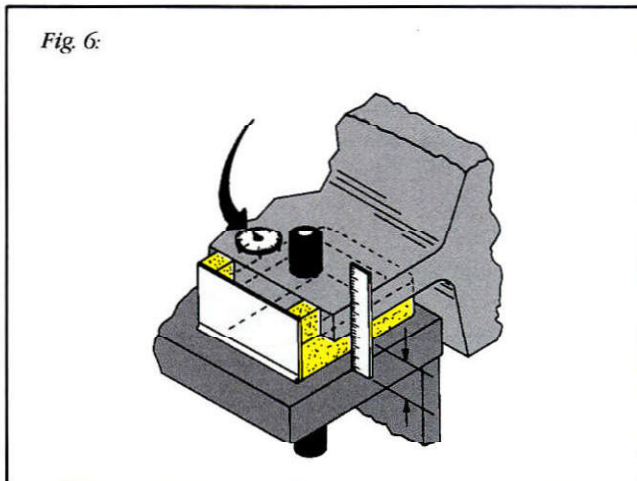

IV. MIXING AND POURING

- Ensure that all damming is complete.
- For CHOCKFAST ORANGE only, decide from the graph the amount of hardener to be used.
- Bring the resin and hardener from storage.
- Put on gloves and eye protection.
- Add the hardener to the resin can. Power mix at about 200 rpm, certainly not over 500 rpm, for 3 minutes using the mixing blade recommended by your distributor. Keep the blade submerged and traversing the can. Make sure the bottom of the can is scoured.
- Pour the resin as soon as possible after mixing. Do not scrape out the residue from the can sides and bottom.

Fig. 7: Mix Resin and Hardener for 2-3 Minutes

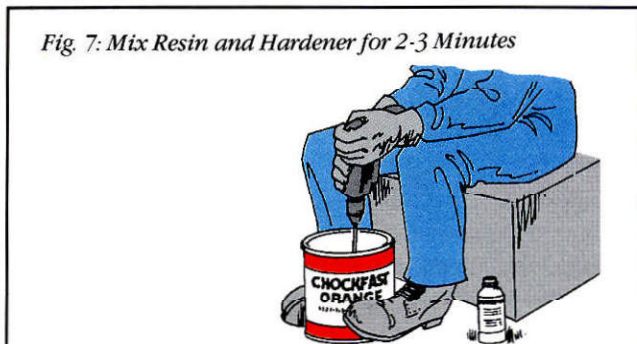
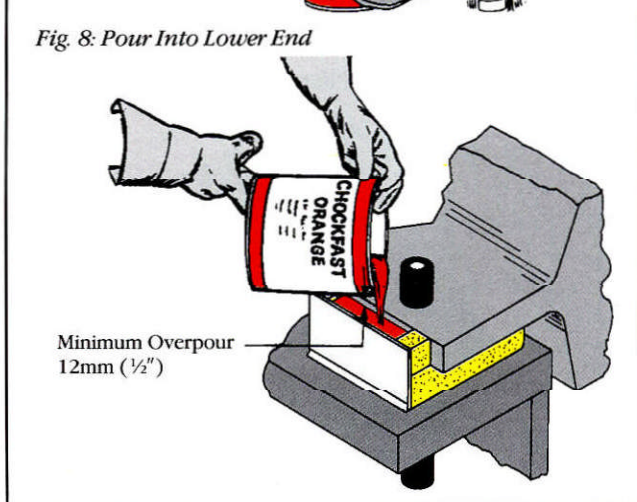

Fig. 8: Pour Into Lower End



V. AFTER POURING

1. Leaks can start at any time while the resin is still liquid. So, do not leave the machine until all the chocks have gone hard.
2. Make sure the temperature is at least 13°C (55°F), use heaters if necessary, and leave the chocks to cure. Allow at least the following time:

13°C-18°C (55°F-65°F)	48 hours
19°C-21°C (66°F-70°F)	24 hours
Above 21°C (70°F)	18 hours
3. When satisfied sufficient cure has taken place, remove the heaters, if used. Allow the chocks to come to ambient temperature.
4. Remove the front dams. Take the sharp edge off the overpour.
5. Release the jack screws, wedges or other alignment supports.
6. Tighten the hold down bolts to the desired tension or torque.

7. Fit the measuring pins if alignment is critical.

NOTE: CHOCKFAST ORANGE ONLY

Under some circumstances a reduced amount of hardener is used. Refer to Bulletin 693, excerpted below, or consult a Chockfast distributor for guidance. Because there are so many variables in chock size, chock thickness, metal temperature, heat sink, etc., it is advantageous to condition the resin to 20°C - 25°C (68°F - 77°F). The decision on exactly how much hardener to use is to be made by the technician in charge. Bulletin 693 and the graph below are a guide only.

For chocks less than 20mm (3/4 in.) thick always use full hardener. For chocks less than 12mm (1/2 in.) or chocks that must be poured in layers consult a Chockfast distributor for advice. Always use maximum hardener with Chockfast Gray.

TECHNICAL SERVICE AND SUPERVISION ARE READILY AVAILABLE. CONTACT YOUR LOCAL DISTRIBUTOR.

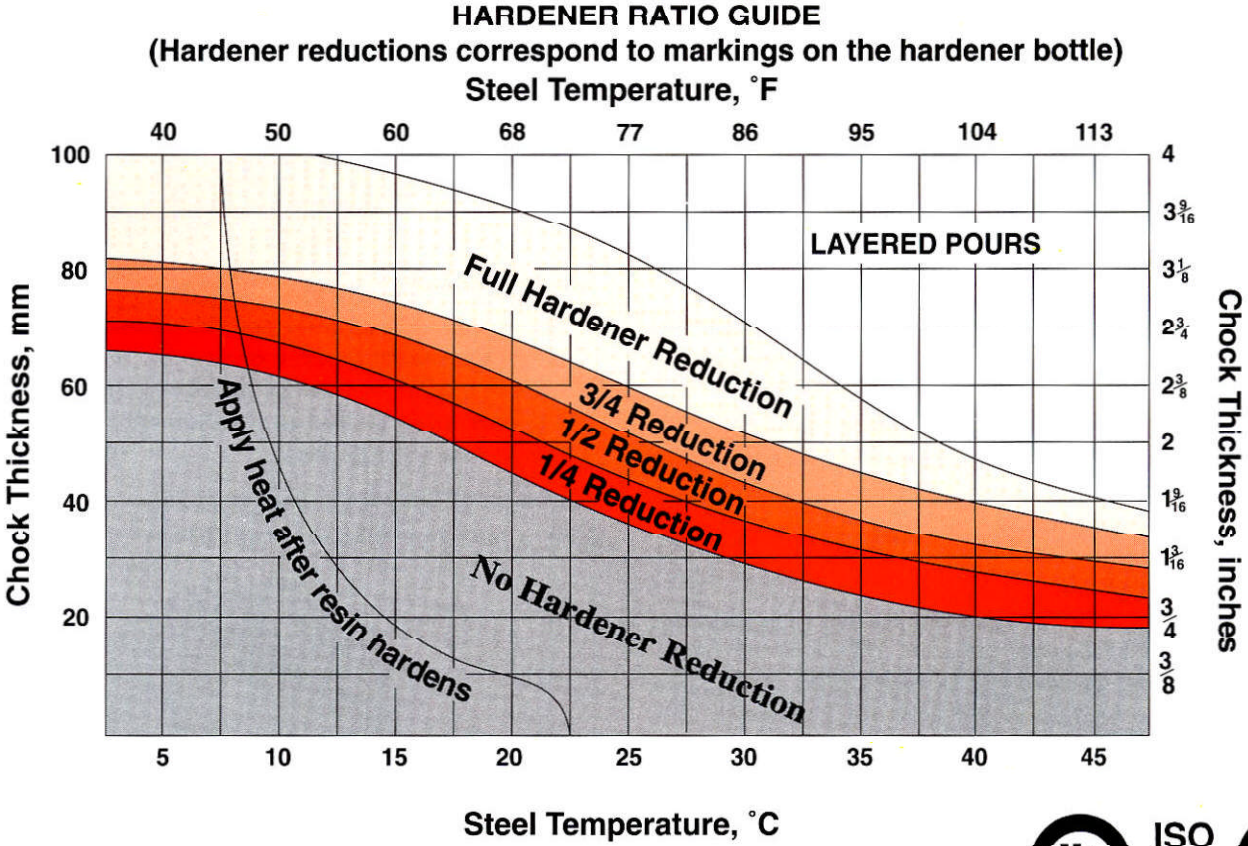

130 Commerce Drive • Montgomeryville, PA 18936 • 215.855.8450 • Fax 215.855.4688



All printed statements, data and recommendations are based on reliable information and tests, and are presented without any guarantee or warranty. Statements regarding the use of ITW Philadelphia Resins' products and processes are not to be construed as recommendations for use in violation of any applicable laws, regulations or patent rights. © All rights reserved.